

FORD MOTOR COMPANY

ENGINEERING STAFF-DEARBORN, MICHIGAN



WIRING COLOR CODE

(20) YELLOW RED TR.

FDA-14412-A ASSY

11654 ASSY (REF.)

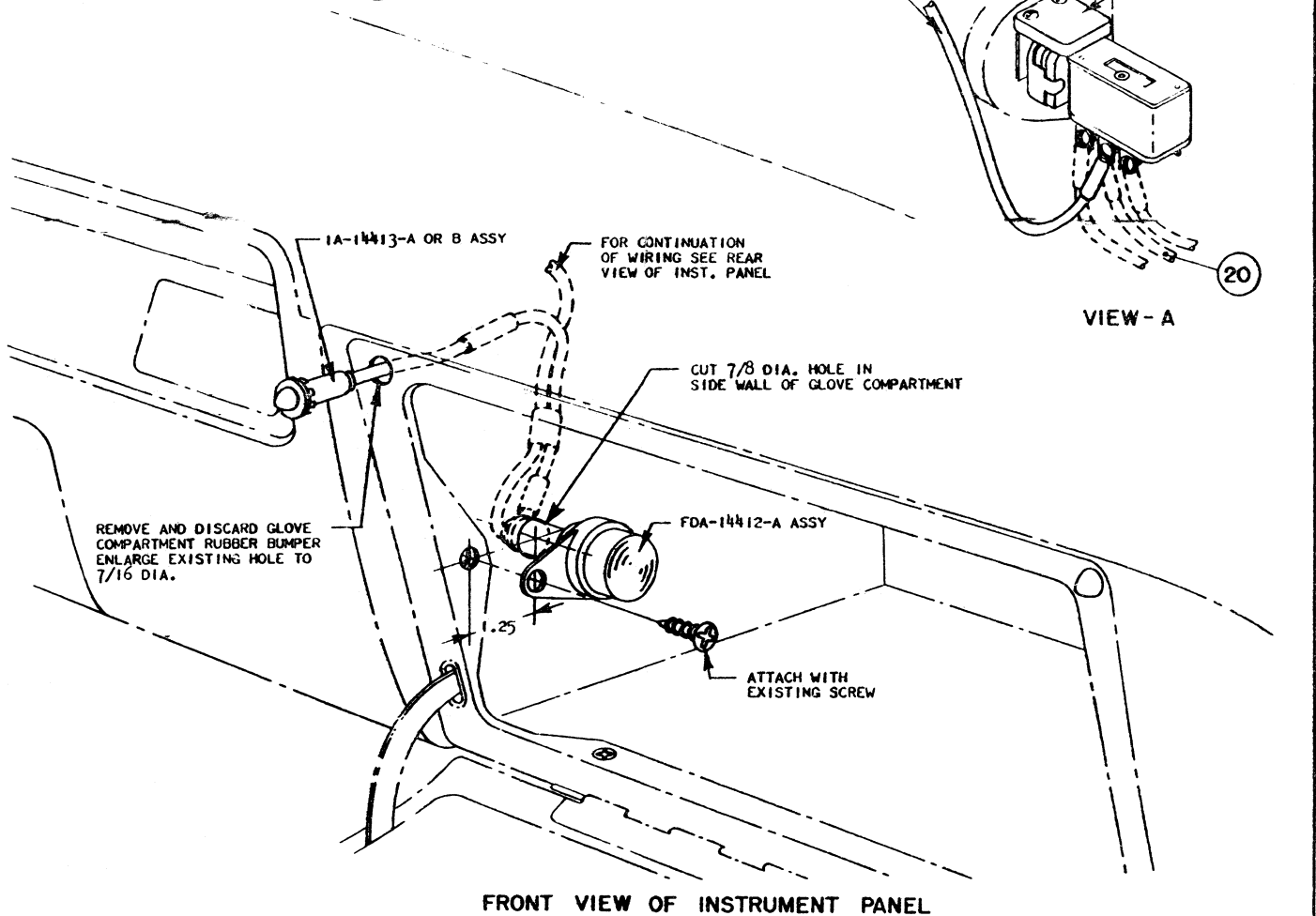

FRONT VIEW OF INSTRUMENT PANEL

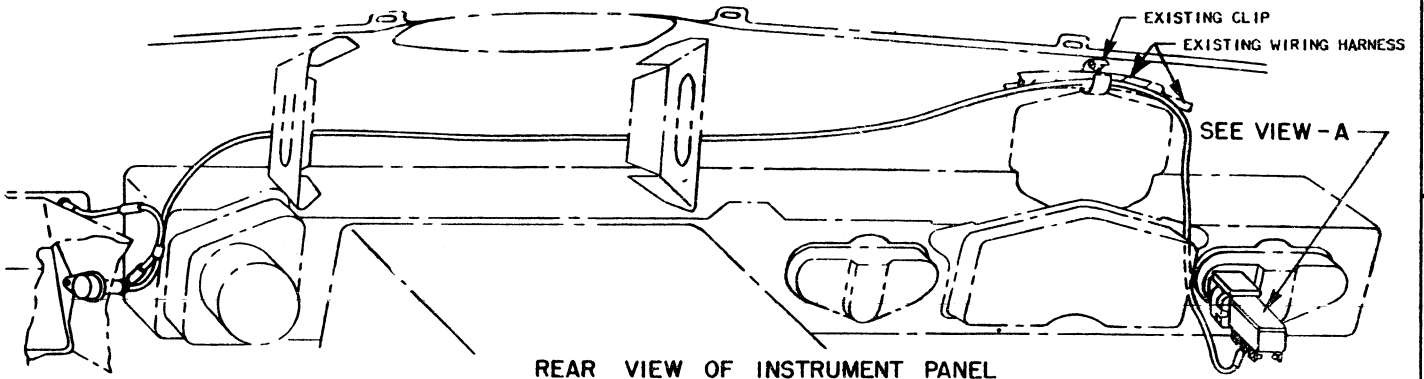

REAR VIEW OF INSTRUMENT PANEL

1. LOCATE AND CUT 7/8 (.88) DIA. HOLE AS SHOWN.
2. MOUNT LAMP WITH EXISTING SCREW AS SHOWN.
3. ENLARGE EXISTING BUMPER HOLE TO 7/16 DIA.
4. ROUTE LAMP GROUND WIRE THROUGH SWITCH HOLE ATTACH WIRE TO SWITCH AND SNAP SWITCH INTO HOLE AS SHOWN.
5. ROUTE & ATTACH LAMP FEED WIRE FDA-14412-A ASSY TO HEADLAMP SWITCH AS SHOWN.

FDA-18254-A KIT - GLOVE COMPARTMENT LAMP
CONSISTS OF:

PART NUMBER	PART NAME	REQD.
FDA-14412-A	LAMP AND WIRING ASSY	1
1A-14413-A OR B	SWITCH AND WIRE ASSY	1
SK-FDA-18254-A	INSTALLATION SHEET	1

DATE 6-1-53

INSTALLATION -KIT - GLOVE COMPARTMENT LAMP SK-FDA-18254-A